



Soil-Reinforcement Fabric

- *Economical*
- *Easy Installation*
- *Convenient Roll Sizes*
- *For VERSA-LOK® Walls Up To Eight Feet High*

On many projects, VERSA-LOK retaining walls work as gravity systems, where unit weight provides resistance to earth pressures. Sometimes, unit weight alone is not enough to retain soil – especially in taller projects or walls that support heavy loads. VERSA-LOK Fabric is a low-cost, easily installed geotextile that is specially designed to provide the additional soil reinforcement necessary for many of these applications.

Before constructing a wall, please carefully read this brochure and VERSA-LOK's *Design & Installation Guidelines* – available from your local VERSA-LOK representative or by calling toll free (800) 770-4525.



Important

Retaining wall designs vary significantly with different site, soil, and loading conditions. Therefore, the drawings presented here are for estimating purposes only and should not be used for final construction. The user is responsible for obtaining final designs from a qualified, licensed civil engineer and for complying with all local building codes.

Use these drawings to help estimate the amount and placement of fabric necessary for your VERSA-LOK retaining wall project. Note that some designs require 4.5-foot rolls while others require 6.0-foot rolls. Never substitute 4.5-foot fabric in place of 6.0-foot fabric.

VERSA-LOK Fabric should not be used on any projects that do not exactly meet the assumptions of these drawings – including taller walls, walls with steeper slopes, walls with larger loads, shoreline applications, and tiered walls. If your project varies from the drawings, in any way, contact your local VERSA-LOK representative for other soil-reinforcement options or call us toll free at (800) 770-4525.

Use 4.5-foot VERSA-LOK Fabric for these walls...

Height: 3 feet

Loading: Slope with no additional load.

Fabric placement: One layer of 4.5-foot fabric – at top of third course from bottom.

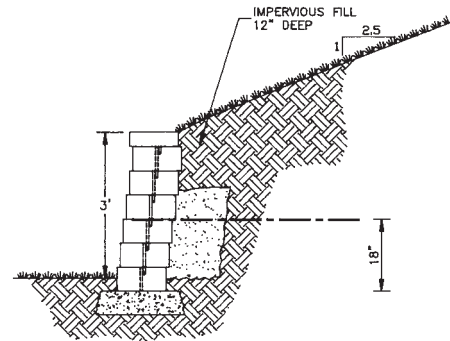

Height: 3 feet

Loading: Level backfill with load.

Fabric placement: One layer of 4.5-foot fabric – at top of third course from bottom.

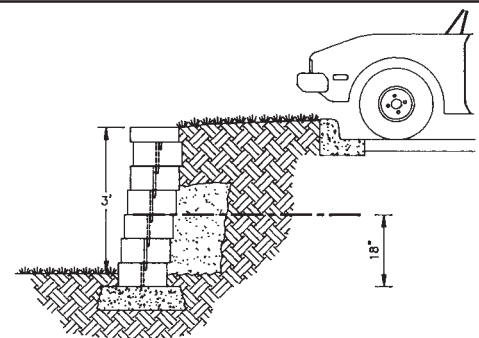

Height: 5 feet

Loading: Level backfill with no additional load.

Fabric placement: Two layers of 4.5-foot fabric – at top of second and fifth courses from bottom.

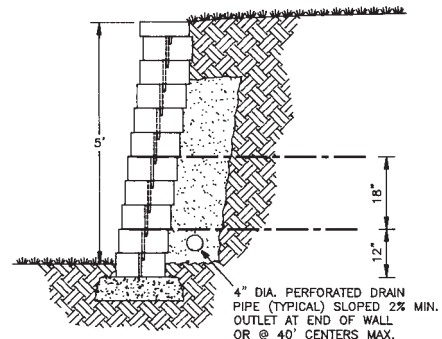



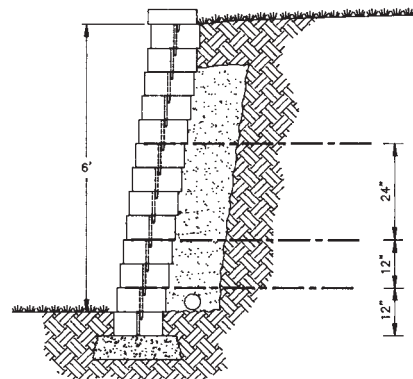

Height: 6 feet

Loading: Level backfill with no additional load.

Fabric placement: Three layers of 4.5-foot fabric – at top of second, fourth, and eighth courses from bottom.



LEGEND

	COMPACTED BACKFILL		VERSA-LOK FABRIC
	3/4" DRAIN AGGREGATE		
	GRANULAR LEVELING PAD		



See back page for installation instructions

Use 6.0-foot VERSA-LOK Fabric for these walls...

Height: 4 feet

Loading: Slope with no additional load or level backfill with load.

Fabric placement: Two layers of 6.0-foot fabric – at top of second and fifth courses from bottom.

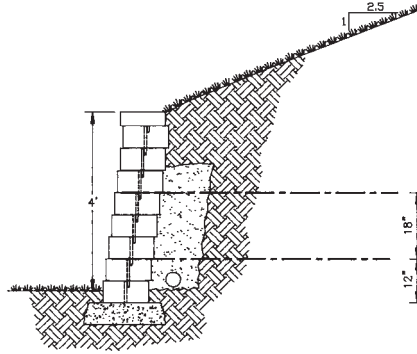

Height: 5 feet

Loading: Slope with no additional load or level backfill with load.

Fabric placement: Three layers of 6.0-foot fabric – at top of first, fourth, and seventh courses from bottom.

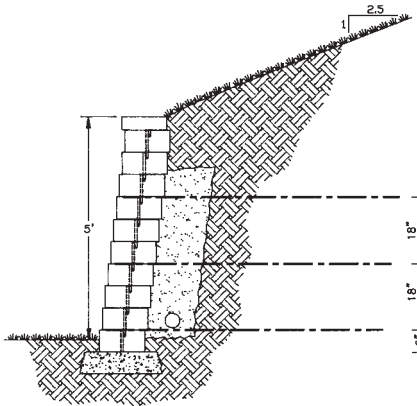

Height: 7 feet

Loading: Level backfill with no additional load.

Fabric placement: Five layers of 6.0-foot fabric – at top of first, third, sixth, ninth, and twelfth courses from bottom.

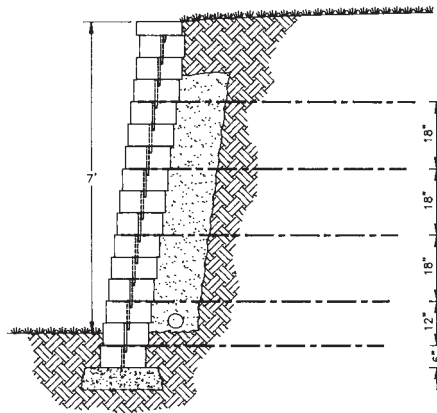

Height: 8 feet

Loading: Level backfill with no additional load.

Fabric placement: Six layers of 6.0-foot fabric – at top of first, third, sixth, ninth, twelfth, and fifteenth courses from bottom.

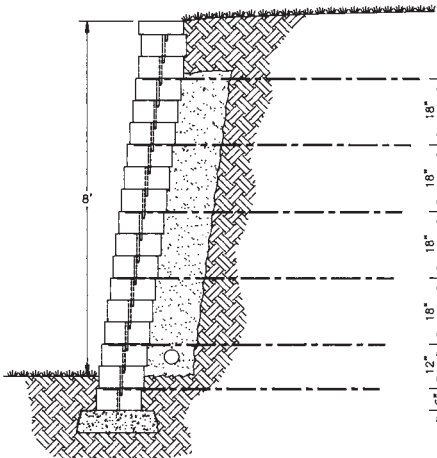

Design Assumptions

These drawings assume the following conditions:

- Stable foundation soils
- No groundwater above the wall base
- Soils with minimum internal friction angle of 28 degrees
- Soil weight of 120 pcf
- No additional loading (including that which may be caused by tiered retaining walls)

Slopes must not be steeper than 2.5:1 (horizontal:vertical). Where traffic loading is present, loads must be back at least two feet from the back of the wall and the loads must not exceed a uniform 100 psf (light car traffic).

 The drawings in this guide apply only to VERSA-LOK Fabric used in conjunction with VERSA-LOK Standard retaining wall units and VERSA-TUFF® pins. Do not use these drawings as guides for any other soil-reinforcement material or any other retaining wall units. Remember that final designs should be approved by a qualified, licensed civil engineer in accordance with all local building codes.



VERSA-LOK Soil-Reinforcement Fabric Installation Instructions

Before proceeding, please obtain a copy of VERSA-LOK's *Design & Installation Guidelines* and, if installing curves or corners, a copy of VERSA-LOK's *Technical Bulletin #3 – "Curves and Corners."* Thoroughly review all design and construction fundamentals and begin wall construction according to the guidelines illustrated in these documents. Use the following instructions when it is time for placement of soil-reinforcement materials.

Prepare to install VERSA-LOK Soil-Reinforcement Fabric by placing VERSA-LOK units and backfilling up to the height of the first (lowest) soil-reinforcement layer specified on final construction drawings (Figure 1).

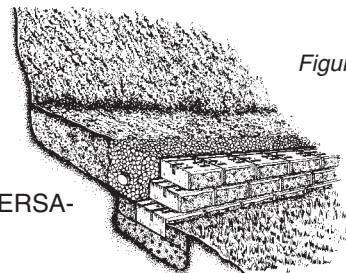

Figure 1

Lay VERSA-LOK Fabric on top of the compacted backfill and VERSA-LOK units by rolling it out parallel to the wall. Keep the fabric one inch behind the front face of the wall so that it completely covers the holes and slots in the VERSA-LOK units (Figure 2).

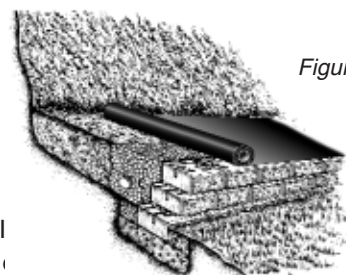



Figure 2

 Placing soil-reinforcement fabric behind curves and corners requires special layout and overlapping procedures. Never overlap soil-reinforcement layers directly on top of each other. Slick surfaces of the fabric will not hold in place properly when placed directly next to each other. Always provide at least three inches of soil fill between overlapping fabric layers. See illustrations in VERSA-LOK *Technical Bulletin #3* for correct placement of fabric in curves or corners.

Correctly position the next course of VERSA-LOK units on top of the fabric. Insert VERSA-TUFF pins and drive them through the fabric into the receiving slots in adjacent lower course units. Use an extra pin and a mallet to make sure that the pins are firmly seated in the lower course units.

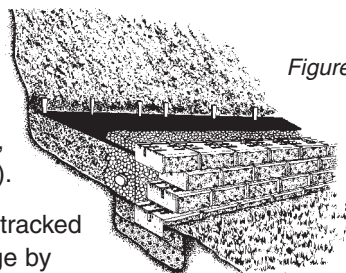

Figure 3

Place drainage aggregate against back of units and on top of soil-reinforcement fabric. Remove slack by pulling the fabric backward from the wall face and anchoring at back edge (Figure 3). Beginning at the drainage aggregate, place and compact soil backfill. Keep fabric taut and avoid wrinkles (Figure 4).

Place at least a six-inch layer of soil backfill before using any rubber-tired or tracked equipment on top of the fabric area. Prevent fill movement and fabric damage by driving equipment slowly and turning gradually. Use only hand-operated compaction equipment within three feet of the wall face to avoid excessive equipment loads and possible wall movement.

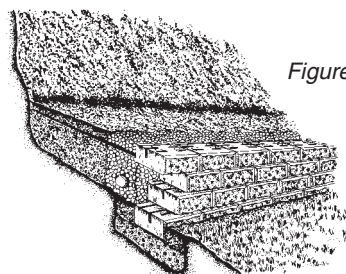

Figure 4

Continue placing additional courses, drainage material, compacted soil backfill, and VERSA-LOK Fabric according to final construction drawings. Do not stack more than two courses without backfilling. At the top, place and compact a 12-inch layer of impervious fill over the drainage aggregate, install cap units, and complete final grading.

www.bendindustries.com



Premium Retaining Walls for governmental, commercial, and residential applications.

Made worldwide under license from VERSA-LOK Retaining Wall Systems. U.S. Patent D319,885, U.S. Patent D321,060, U.S. Patent D341,215, U.S. Patent D346,667, U.S. Patent D378,702, U.S. Patent D391,376, and other U.S. patents pending; Canadian Industrial Design Registration No. 63929, No. 71472, No. 73910, No. 73911, No. 73912, No. 77816, No. 79058, and No. 82288.